

NOTA:  
- TODAS LAS MEDIDAS ESTAN EN mm

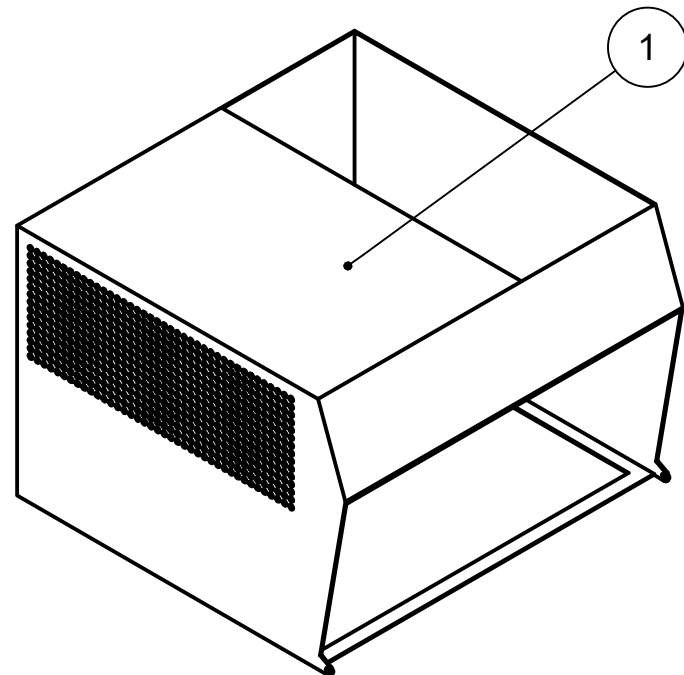
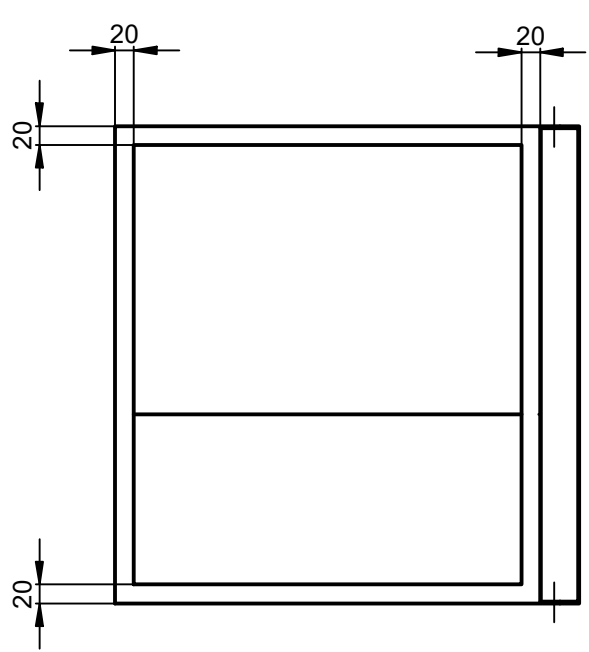

2	COMPUERTA CONTENEDOR DE CAFÉ	1	A3-002	ACERO INOXIDABLE 304	500 X 460 X 231.6	FABRICACIÓN LOCAL
1	CONTENEDOR DE CAFÉ	1	A3-002	ACERO INOXIDABLE 304	505 X 465 X 350	FABRICACIÓN LOCAL
Ref.	Descripción	Cantidad	Plano Ref.	Material	Especificaciones	Observaciones

UNIVERSIDAD DE ANTIOQUIA

FACULTAD DE INGENIERÍA

DEPARTAMENTO DE INGENIERÍA MECÁNICA

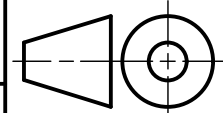

ESC: 1:8

CONTENEDOR DE CAFÉ

ARCHIVO: FCH: 27/07/2020  
TOSTADOR DE CAFÉ O.T.: N/A

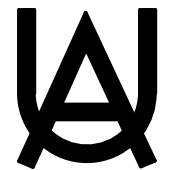

DIS: GRUPO DE TRABAJO

DIB: GRUPO DE TRABAJO

MOD: 001

APRB:

REV:

PL.No: A3-002